



COMPONENTS

- Material: Food approved high density polyethylene
- Standard Color: White (Other colors on request)
- Pour spouts available
- Gasket: EPDM (Ethylene Propylene Diene Monomer)
- Rieke FS-16 All Plastic Flexspout Available

WALL THICKNESS

	cm	inch
• Pail	.229	.090
• Gasket Lid (647)	.241	.095

STANDARD WEIGHT (+/- 2%)

	g	lb.
• Pail (no handle)	982	2.16
• Pail (including plastic handle)	1012	2.23
• Blank Lid Only (no accessories)	395	0.87
• Flexspout Lid Only (no accessories)	393	0.86
• Blank Lid (includes gasket)	427	0.94
• Flexspout Lid (includes gasket & fittings)	445	0.98

IMPORTANT: PLEASE REFER TO UN PACKAGE ASSEMBLY SHEET PRIOR TO USE.

TOP LOADING RESISTANCE

	kg	lb.
• With Lid	250	550

CAPACITIES

VOLUME	Litres	GALLONS	
		Imp.	U.S.
Nominal	20.00	4.40	5.28
Maximum to Overflow	22.98	5.05	6.07
Maximum with Lid	21.03	4.63	5.56

PRODUCT DENSITY g/cm ³	Maximum Weight Filled with Gasket Lid	
	KG	LB
0.5	11.24	24.73
0.6	13.49	29.68
0.7	15.74	34.63
0.8	17.99	39.57
0.9	20.24	44.52
1.0	22.49	49.47
1.1	24.73	54.41
1.2	26.98	59.36
1.3	29.23	64.31
1.4	31.48	69.25
1.5	33.73	74.20

Above is a guideline only.
Customer should verify with specific product to be packaged.

UN CERTIFIED 20 LITRE HEAVY WALL CONTAINER WITH GASKET LID

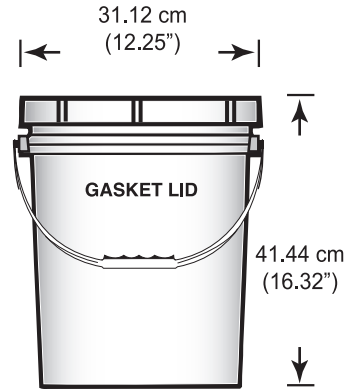

NESTING

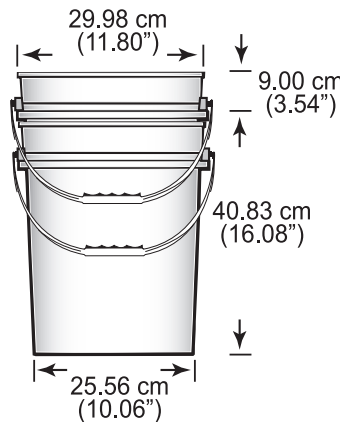

STACKING

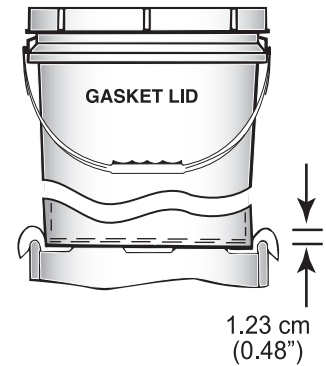

DESIGNATION MARKINGS

Designation Markings of the Pro-Western Plastics UN Lid & 20 Litre Container:

UN 1H2 / Y1.5 / 30 / yy / CAN / PWP1969 2-3224

- UN** United Nation Certified Packaging
- 1H2** Open Head Plastic Drum
- Y** Packaging group II or III
- 1.5** Liquid commodities with specific gravity that does not exceed 1.5
- 30** Capable of withstanding 30kpa of hydrostatic pressure
- yy** Year package was manufactured
- CAN** Country authorizing the mark
- PWP1969** Certification code
- 2-3224** Transport Canada design registration number

PALLET UTILIZATION

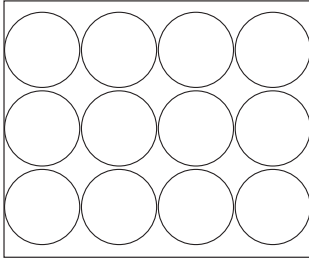

**122 cm x 102 cm
(48" x 40")**

IMPORTANT: Never let pails overlap edge of pallet

RECOMMENDED STACKING HEIGHT

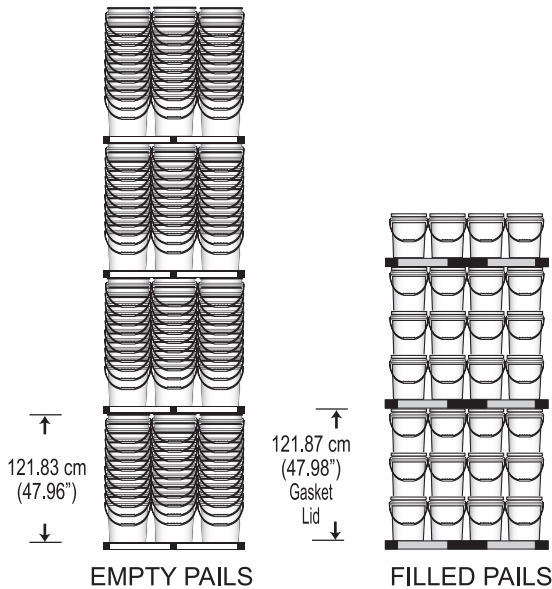

SHIPPING DATA

	747 PAIL	647 GASKET LID
Quantity	120/pallet	30/box
Dimensions*	49.75" x 37.75" x 48.25"	25.25" x 12.75" x 19.00"
Volume	52.44 cu. ft.	3.54 cu. ft.
Weight**	119.34 kg 262.55 lbs	13.62 kg 29.96 lbs

* AND ** DOES NOT INCLUDE WOODEN PALLET
*** BASED ON GASKET LID WITHOUT FITTINGS

OPENING

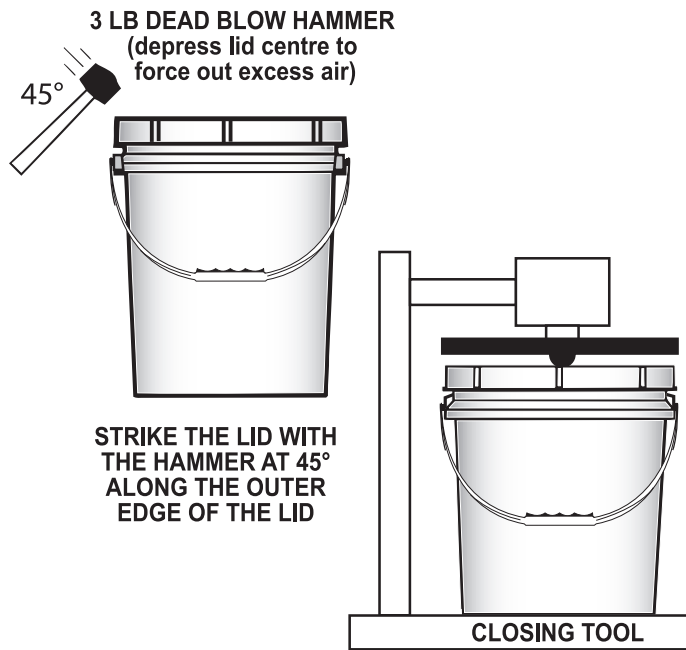
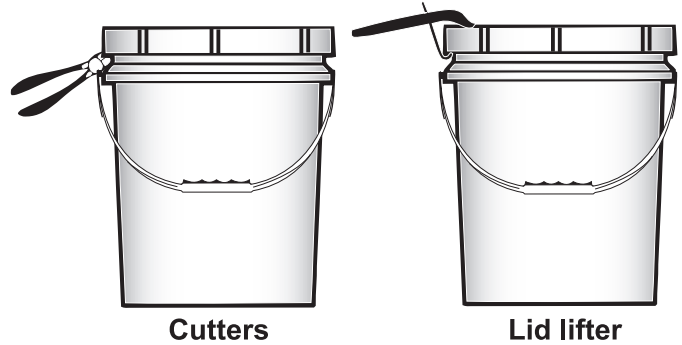

PRINTING

DRY OFFSET PRINTING (UP TO MAXIMUM 4 PANTONE COLORS)

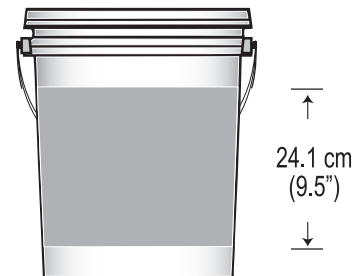

APPROVALS

Pro-Western Plastics Ltd. disclaims any liability for the use of the information and data contained herein. We reserve the right to alter or modify any product and/or specification, at any time.