



COMPONENTS

- Material: Food approved high density polyethylene
- Standard Color: White (Other colors on request)
- Plastic Fingergrip Handle
- Pour spouts available
- Gasket: EPDM (Ethylene Propylene Diene Monomer)

WALL THICKNESS

	cm	inch
• Pail	.185	.073
• Gasket Lid (656)	.196	.077
• Snap-On Lid (642)	.170	.067

STANDARD WEIGHT (+/- 2%)

	g	lb.
• Pail (with handle)	618	1.36
• Gasket Lid (656)	282	0.62
• Snap On Lid (642)	184	0.40

THERMAL RESISTANCE (Tested with water)

- Filling from 38°C (-36°F) to 82°C (180°F)
- Warehousing from -40°C (-40°F) to 39°C (102°F)

TOP LOADING RESISTANCE

	kg	lb.
• With Gasket Lid	250	550
• With Snap On Lid	139	306

CAPACITIES

VOLUME	Litres	GALLONS	
		Imp.	U.S.
Nominal	13.25	2.91	3.50
Maximum to Overflow	14.88	3.27	3.93
Maximum with Gasket Lid	13.83	3.04	3.65
Maximum with Snap-On Lid	13.98	3.07	3.69

PRODUCT DENSITY g/cm ³	Maximum Weight Filled with Lid			
	GASKET LID		SNAP-ON LID	
	kg	lb	kg	lb
0.5	7.36	16.20	7.39	16.26
0.6	8.84	19.44	8.87	19.51
0.7	10.31	22.68	10.35	22.76
0.8	11.78	25.92	11.82	26.01
0.9	13.26	29.16	13.30	29.26
1.0	14.73	32.40	14.78	32.51
1.1	16.20	35.64	16.26	35.77
1.2	17.67	38.88	17.74	39.02
1.3	19.15	42.12	19.21	42.27
1.4	20.62	45.36	20.69	45.52
1.5	22.09	48.60	22.17	48.78

Above is a guideline only.
Customer should verify with specific product to be packaged.

642 SNAP ON LID

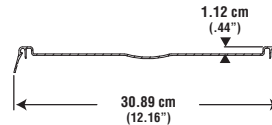

656 GASKET LID

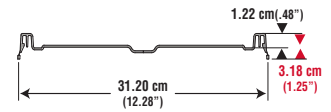

3.5 U.S. GALLON HEAVY WALL CONTAINER

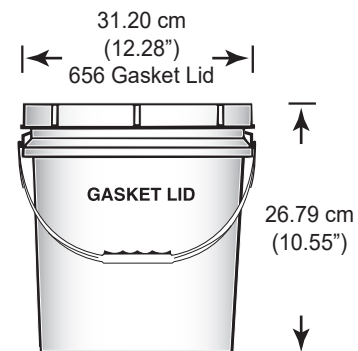
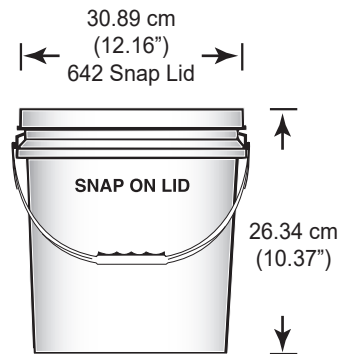

NESTING

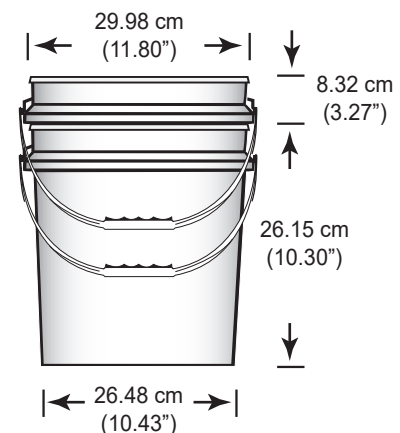

PALLET UTILIZATION

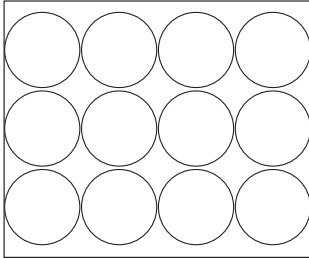

**122 cm x 102 cm
(48" x 40")**

IMPORTANT: Never let pails overlap edge of pallet

RECOMMENDED STACKING HEIGHT

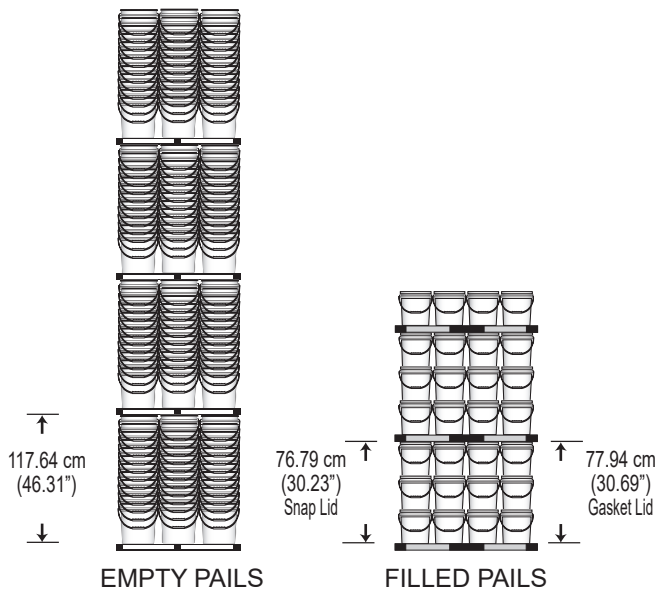

OPENING

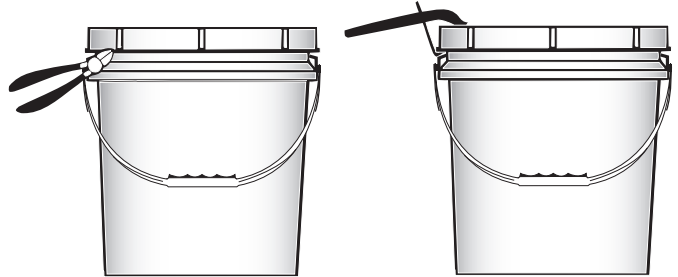

Cutters

Lid lifter

CLOSING

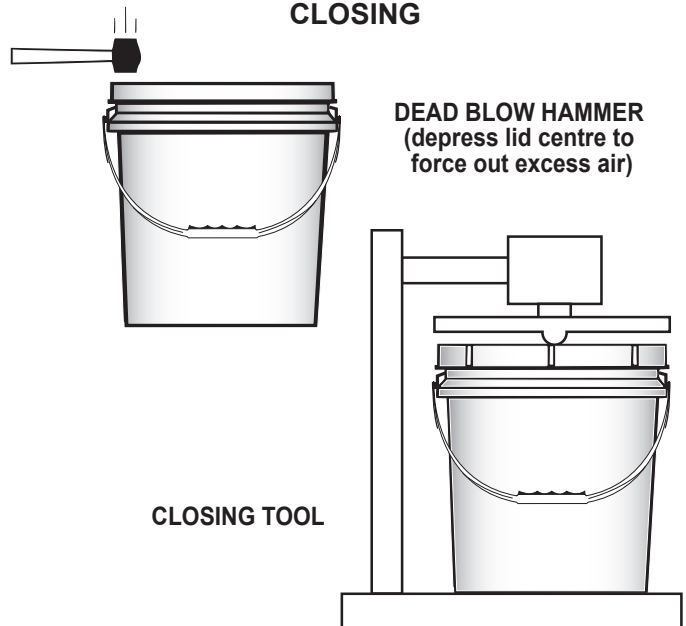

PRINTING

DRY OFFSET PRINTING (UP TO MAXIMUM 4 PANTONE COLORS)

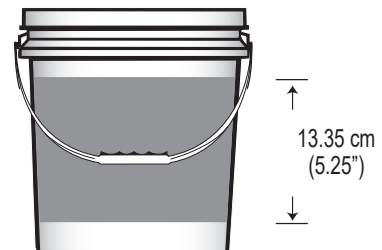

SHIPPING DATA

Quantity	727 PAIL	SNAP LID ⁶⁴²		GASKET LID ⁶⁵⁶	
	144/pallet	60/box	600/plt	40/box	240/plt
Dimensions*	49.75" x 37.75" x 46.75"	25.25" x 12.75" x 19.00"	49.75" x 37.75" x 36.00"	25.25" x 12.75" x 19.00"	49.75" x 37.75" x 18.00"
Volume	50.81 cu. ft.	3.54 cu. ft.	39.13 cu. ft.	3.54 cu. ft.	19.56 cu. ft.
Weight**	90.49 kg 199.08 lbs	11.82 kg 26.00 lbs	111.60 kg 245.52 lbs	12.09 kg 26.69 lbs	69.18 kg 152.20 lbs

* AND ** DOES NOT INCLUDE WOODEN PALLET
*** BASED ON GASKET LID WITHOUT FITTINGS

APPROVALS

Pro-Western Plastics Ltd. disclaims any liability for the use of the information and data contained herein. We reserve the right to alter or modify any product and/or specification, at any time.