



# 710 1 Imperial Gallon Pail

## COMPONENTS

- Material: Food approved high density polyethylene
- Standard Color: White (Other colors on request)
- Plastic Handle
- Gasket: EPDM (Ethylene Propylene Diene Monomer)

## WALL THICKNESS

	cm	inch
• Pail	.145	.057
• Gasket Tear Tab Lid (621)	.135	.053
• Snap-On Tear Tab Lid (622)	.142	.056

## STANDARD WEIGHT (+/- 2%)

	g	lb.
• Pail (including handle)	243	.53
• Gasket Lid (621- including gasket)	87	.19
• Snap-On Tear Tab Lid (622)	71	.16

## THERMAL RESISTANCE (Tested with water)

- Filling from 38°C (-36°F) to 82°C (180°F)
- Warehousing from -40°C (-40°F) to 39°C (102°F)

## TOP LOADING RESISTANCE

	kg	lb.
• With Gasket Lid (621)	95	209
• With Snap-On Lid (622)	100	220

## CAPACITIES

VOLUME	Litres	GALLONS	
		Imp.	U.S.
Nominal	4.55	1.00	1.20
Maximum to Overflow	5.46	1.20	1.44
Maximum with Gasket Lid	5.06	1.11	1.34
Maximum with Snap-On Lid	5.16	1.13	1.36

PRODUCT DENSITY g/cm <sup>3</sup>	Maximum Weight Filled with Lid			
	GASKET		SNAP-ON	
	kg	lb	kg	lb
0.5	2.69	5.93	2.74	6.02
0.6	3.23	7.11	3.28	7.22
0.7	3.77	8.30	3.83	8.43
0.8	4.31	9.48	4.38	9.63
0.9	4.85	10.67	4.92	10.83
1.0	5.39	11.85	5.47	12.04
1.1	5.93	13.04	6.02	13.24
1.2	6.46	14.22	6.56	14.44
1.3	7.00	15.41	7.11	15.65
1.4	7.54	16.59	7.66	16.85
1.5	8.08	17.78	8.21	18.05

Above is a guideline only.  
Customer should verify with specific product to be packaged.

## 622 SNAP ON LID

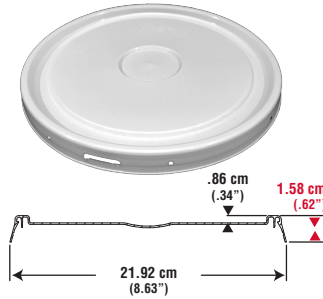

## 621 GASKET LID

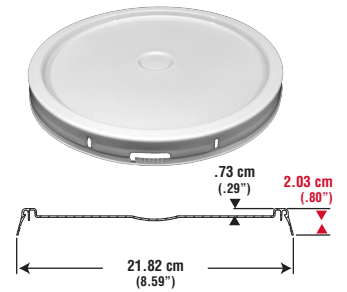

## HEAVY DUTY 1 IMPERIAL GALLON

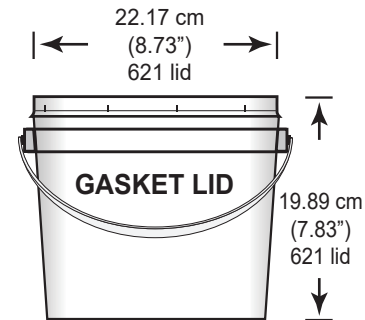
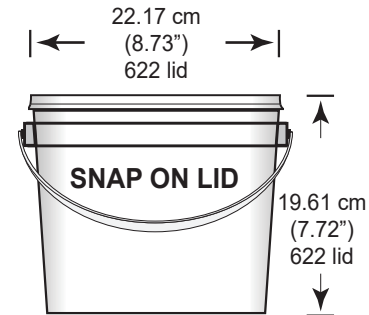

## NESTING

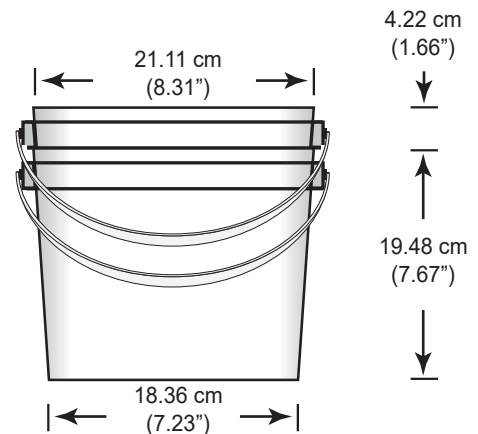

**PALLET UTILIZATION**

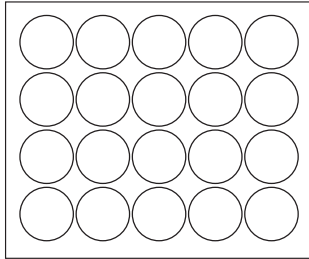

**122 cm x 102 cm  
(48" x 40")**

**IMPORTANT: Never let pails overlap edge of pallet**

**RECOMMENDED STACKING HEIGHT**

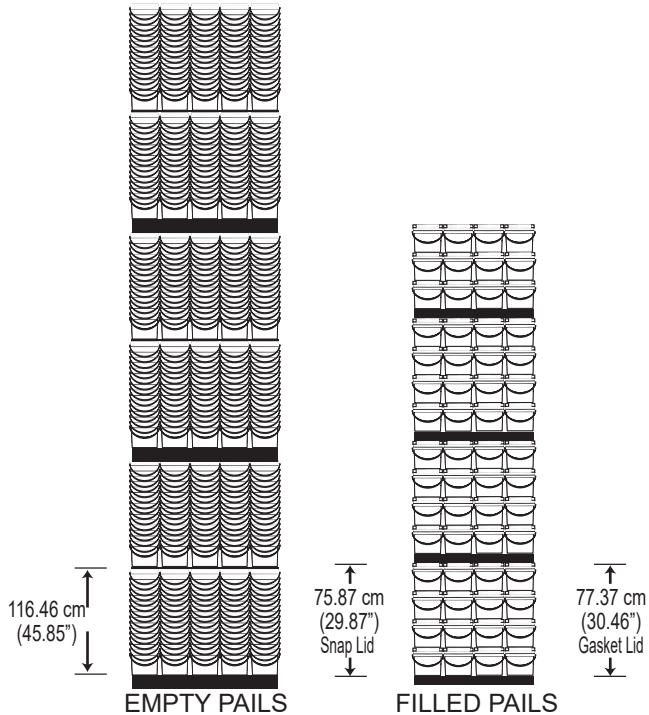

**OPENING**

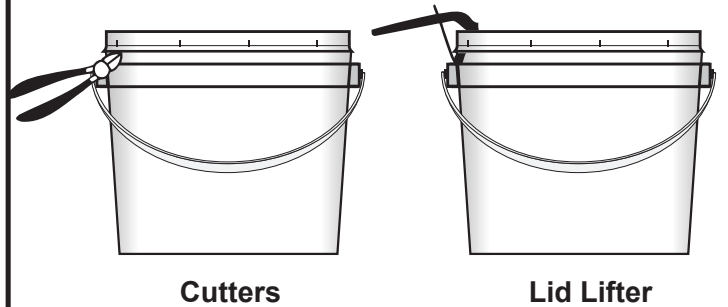

**Cutters**

**Lid Lifter**

**CLOSING**

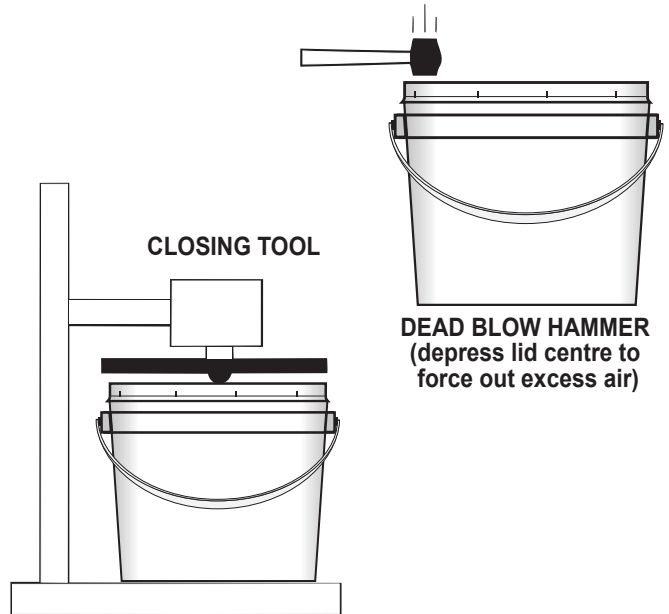

**CLOSING TOOL**

**DEAD BLOW HAMMER  
(depress lid centre to  
force out excess air)**

**PRINTING**

**DRY OFFSET PRINTING (UP TO MAXIMUM 4 PANTONE COLORS)**

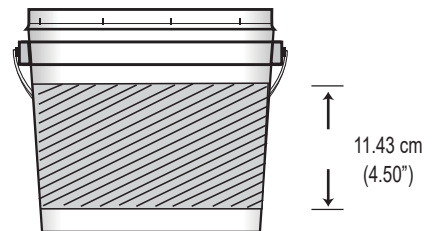

**SHIPPING DATA**

	<b>710 PAIL</b>	<b>SNAP TT (622)</b>	<b>SNAP TT (622)</b>	<b>GASKET TT (621)</b>	<b>PAIL &amp; LID (710 PKG)</b>
<b>Quantity</b>	696/pallet	180/box	1440/pallet	180/box	45/box (622 Snap)
<b>Dimensions*</b>	52.50" x 42.50" x 46.25"	24.00" x 20.00" x 11.75"	49.75" x 38.00" x 19.25"	24.00" x 20.00" x 19.00"	24.00" x 20.00" x 25.25"
<b>Volume</b>	59.72 cu. ft.	3.26 cu. ft.	21.06 cu. ft.	5.28 cu. ft.	7.01 cu. ft.
<b>Weight**</b>	178.03 kg 391.67lbs	13.73 kg 30.20 lbs	103.74 kg 228.23 lbs	16.71 kg 36.76 lbs	15.52 kg 34.14 lbs

\* AND \*\* DOES NOT INCLUDE WOODEN PALLET

**APPROVALS**

Pro-Western Plastics Ltd. disclaims any liability for the use of the information and data contained herein. We reserve the right to alter or modify any product and/or specification, at any time.