



**COMPONENTS**

- Material: Food approved high density polyethylene
- Standard Color: White (Other colors on request)
- Plastic Handle with Finger Grip
- Gasket: EPDM (Ethylene Propylene Diene Monomer)

<b>WALL THICKNESS</b>	cm	inch
• Pail	.186	.073
• Gasket Lid TT (633)	.162	.064
• Snap On TT Lid (632)	.163	.064
• Snap On Lid (631)	.159	.063

<b>STANDARD WEIGHT (+/- 2%)</b>	g	lb.
• Pail (including handle)	704	1.55
• Gasket Lid TT (633) includes gasket	168	0.37
• Snap On TT Lid (632)	152	0.33
• Snap On Lid (631)	129	0.28

<b>THERMAL RESISTANCE (Tested with water)</b>	
• Filling	from -38°C (-36°F) to 82°C (180°F)
• Warehousing	from -40°C (-40°F) to 39°C (102°F)

<b>TOP LOADING RESISTANCE</b>	kg	lb.
• With Gasket TT Lid	70	154
• With Snap On TT Lid	70	154
• With Snap On Lid	70	154

**CAPACITIES**

VOLUME	Litres	GALLONS	
		Imp.	U.S.
Nominal	15.14	3.33	4.00
Maximum to Overflow	16.55	3.64	4.37
Maximum with Gasket TT Lid	16.05	3.53	4.24
Maximum with Snap On TT Lid	15.85	3.49	4.19
Maximum with Snap On Lid	15.75	3.46	4.16

PRODUCT DENSITY g/cm <sup>3</sup>	Maximum Weight Filled with Lid					
	GASKET TT LID		SNAP ON TT LID		SNAP ON LID	
	kg	lb	kg	lb	kg	lb
0.5	8.46	18.61	8.35	18.37	8.29	18.24
0.6	10.15	22.33	10.02	22.05	9.95	21.88
0.7	11.84	26.05	11.69	25.72	11.60	25.53
0.8	13.53	29.78	13.36	29.40	13.26	29.18
0.9	15.23	33.50	15.03	33.07	14.92	32.83
1.0	16.92	37.22	16.70	36.74	16.58	36.47
1.1	18.61	40.94	18.37	40.42	18.24	40.12
1.2	20.30	44.66	20.04	44.09	19.89	43.77
1.3	21.99	48.39	21.71	47.77	21.55	47.41
1.4	23.69	52.11	23.38	51.44	23.21	51.06
1.5	25.38	55.83	25.05	55.12	24.87	54.71

Above is a guideline only.  
Customer should verify with specific product to be packaged.

**4 U.S. GALLON SQUARE CONTAINER**

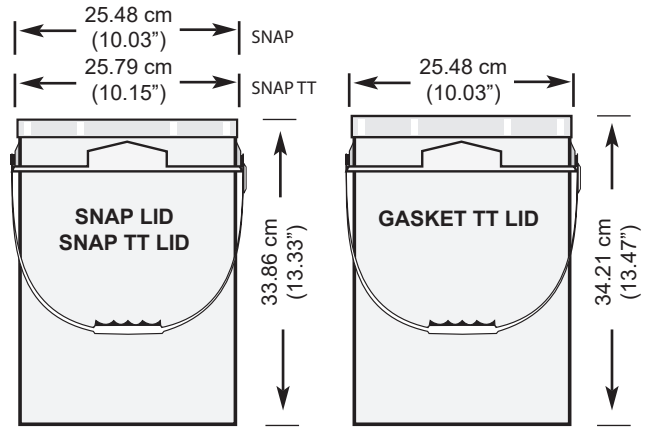

**NESTING**

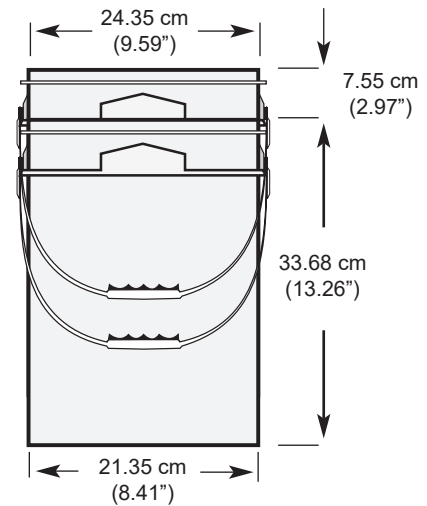

**STACKING**

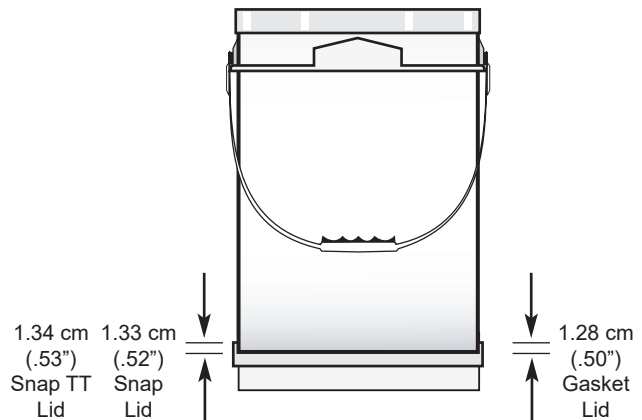

**PALLET UTILIZATION**

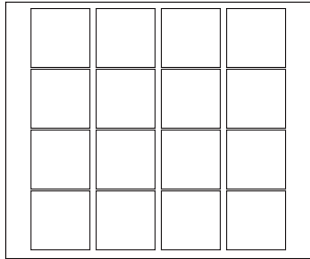

**122 cm x 102 cm  
(48" x 40")**

**IMPORTANT: Never let pails overlap edge of pallet**

**RECOMMENDED STACKING HEIGHT**

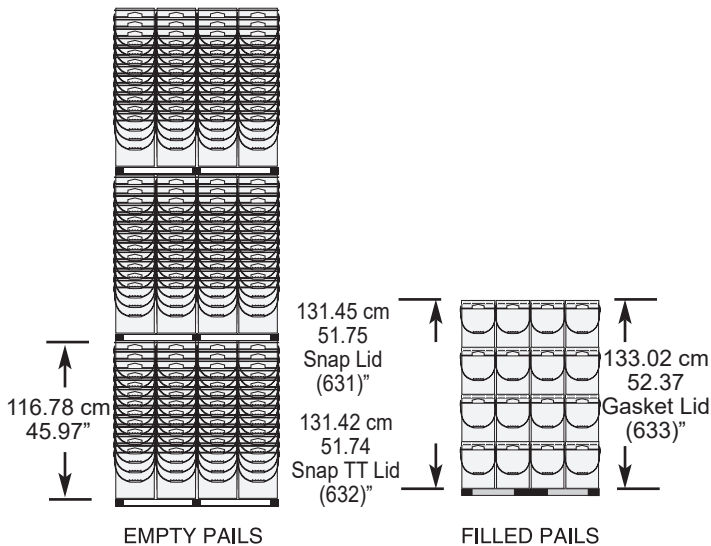

**SHIPPING DATA**

	433 Square	SNAP LID 631	SNAP TT LID 632	SNAP TT LID 632	GASKET LID 633
<b>Quantity</b>	240/pallet	120/box	80/box	1200/pallet	80/box
<b>Dimensions*</b>	52.50" x 42.50" x 46.25"	20.25" x 10.25" x 29.00"	20.25" x 10.25" x 24.75"	52.50" x 42.50" x 13.00"	20.25" x 10.25" x 24.75"
<b>Volume</b>	59.72 cu. ft.	3.48 cu. ft.	2.97 cu. ft.	16.79 cu. ft.	2.97 cu. ft.
<b>Weight**</b>	170.54 kg 375.19 lbs	16.27 kg 35.79 lbs	12.86 kg 28.29 lbs	183.98 kg 404.768 lbs	14.14 kg 31.11 lbs

\* and \*\* Does not include wooden pallet

**OPENING**

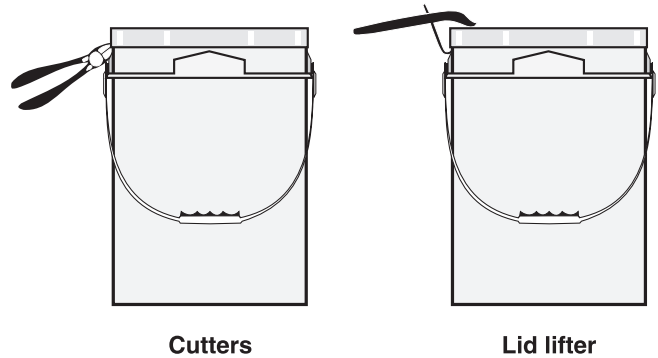

**CLOSING**

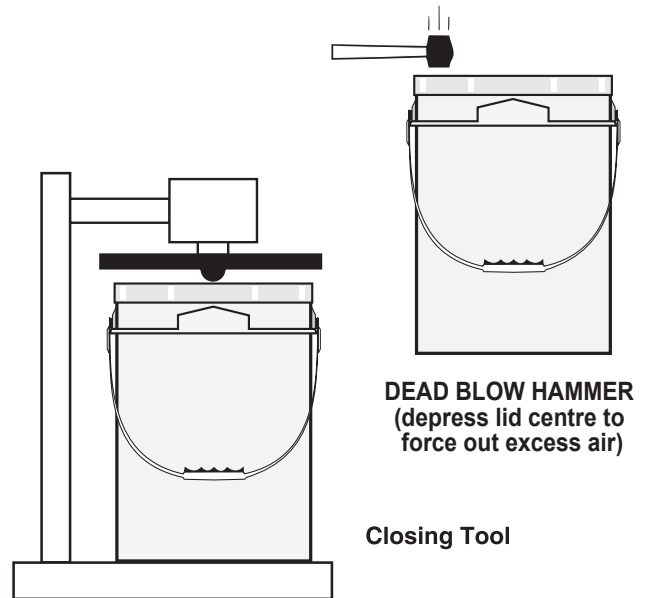

**DECORATION**

Printing not available at this time

**APPROVALS**

Pro-Western Plastics Ltd. disclaims any liability for the use of the information & data contained herein. We reserve the right to alter or modify any product &/or specification, at any time.